

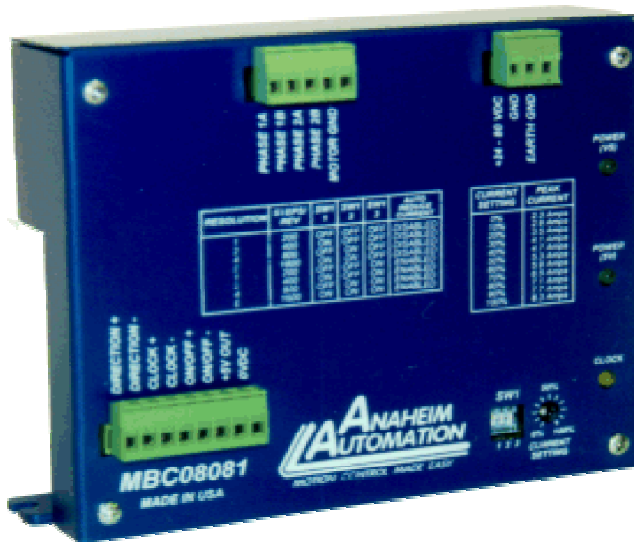

## USER'S MANUAL

### MODEL MBC08081 MICROSTEP DRIVER



ANAHEIM AUTOMATION  
910 E. Orangefair Lane  
Anaheim, CA 92801  
TEL (714) 992-6990  
FAX (714) 992-0471

E-Mail: [sales@anaheimautomation.com](mailto:sales@anaheimautomation.com)  
[www.anaheimautomation.com](http://www.anaheimautomation.com)

#### COPYRIGHT

Copyright 2000 by Anaheim Automation. All rights reserved. No part of this publication may be reproduced, transmitted, transcribed, stored in a retrieval system, or translated into any language, in any form or by any means, electronic, mechanical, magnetic, optical, chemical, manual, or otherwise, without the prior written permission of Anaheim Automation, 910 E. Orangefair Lane, Anaheim, CA 92801.

#### DISCLAIMER

Though every effort has been made to supply complete and accurate information in this manual, the contents are subject to change without notice or obligation to inform the buyer. In no event will Anaheim Automation be liable for direct, indirect, special, incidental, or consequential damages arising out of the use or inability to use the product or documentation.

*Anaheim Automation's general policy does not recommend the use of its products in life support applications wherein a failure or malfunction of the product may directly threaten life or injury. Per Anaheim Automation's Terms and Conditions of Sales, the user of Anaheim Automation products in life support applications assumes all risks of such use and indemnifies Anaheim Automation against all damages.*

#### LIMITED WARRANTY

All Anaheim Automation products are warranted against defects in workmanship, materials and construction, when used under Normal Operating Conditions and when used in accordance with specifications. This warranty shall be in effect for a period of twelve months from the date of purchase or eighteen months from the date of manufacture, whichever comes first. Warranty provisions may be voided if the products are subjected to physical damage or abuse.

Anaheim Automation will repair or replace at its option, any of its products which have been found to be defective and are within the warranty period, provided that the item is shipped freight prepaid, with RMA (return material authorization), to Anaheim Automation's plant in Anaheim, California.

## TABLE OF CONTENTS

---

	PAGE
INTRODUCTION .....	2
ORDERING INFORMATION .....	3
DESCRIPTION .....	4
TERMINAL DESCRIPTION TB1 .....	4
TERMINAL DESCRIPTION (TB2 & TB3) & DIMENSIONS .....	5
WIRING DIAGRAM .....	6
SPECIFICATIONS .....	7
OUTPUT CURRENT .....	8
DETERMINING OUTPUT CURRENT .....	8
SETTING OUTPUT CURRENT .....	8
REDUCING OUTPUT CURRENT .....	9
MOTOR SELECTION .....	9
STEP MOTOR CONFIGURATION .....	9
STEP MOTOR CONNECTION .....	10
POWER CONNECTIONS .....	13
ANAHEIM AUTOMATION STEP MOTOR SELECTION .....	14
MICROSTEP SELECTION .....	15
OPTICALLY ISOLATED INPUTS .....	15
TORQUE/SPEED CURVES .....	16

## INTRODUCTION

The MBC08081 Microstep Motor Driver has an output current capability of 2.3 Amps minimum to 8.3 Amps maximum (Peak Rating). The MBC08081 driver will operate from +24VDC minimum to +85VDC maximum. The inputs are optically isolated with a minimum sourcing of 1mA per input (+5VDC minimum to +24VDC maximum). The clock input is set to receive negative edge clocks with a maximum frequency of 100KHz. The direction input is current sourcing for CW and no current for CCW. The ON/OFF feature is current sourcing to de-energize the step motor and no current to energize the step motor. Reduce Current Enabled automatically reduces Motor current to 70% of set value after last step (920msec delay). The driver has built-in features to indicate power on (Green LEDs) and Clocks being received, greater than 100 Hz (Yellow LED).

The MBC08081 will deliver a peak current of 8.3 Amperes per phase at +85 Volts, providing outstanding motor performance. This advanced technology reduces ripple current while maintaining the 20kHz chopping frequency in the motor, causing less heat in both the motor and drive.

With the MBC08081, various step resolutions can be implemented by the onboard dip switch. These divisions range from 200 steps per revolution to 1600 steps per revolution. The bipolar drive configuration handles 4, 6, and 8 lead motors. Protection devices have been added to this driver for *Phase to Phase Short-Circuit* conditions.

### Microstep Driver features include:

- Size (7.125"L x 1.7"W x 5.52"H)
- Input Voltage +24 to +85VDC
- Output Current 8.3 Amps Peak
- 200 to 1600 steps/rev (1,2,4 and 8 selectable step operations)
- Short Circuit Protection
- No Minimum Inductance
- Optical Isolation
- Motor ON/OFF input

**ORDERING INFORMATION FOR ANAHEIM AUTOMATION  
MICROSTEP DRIVERS AND ACCESSORIES**

1.5 Amp Microstep Driver	MBC158
1.5 Amp Microstep Driver	MBC15161
<b>8.3 Amp Microstep Driver</b>	<b>MBC08081 (featured)</b>
40VDC Power Supply	PSA40V4A
65VDC Power Supply	PSA65V5A
80VDC Power Supply	PSA80V4A
Shielded Motor Cable	AA129010S

**Model MBC158**

This microstep driver is a Single Axis, 1.5 Amp Driver. The MBC158 requires a DC power supply of 12 volts to 48 volts. The PSA40V4A is the recommended Anaheim Automation power supply . The power supply must be ordered separately. Divide- by- 8 Maximum.

**Model MBC15161**

This microstep driver is a Single Axis, 1.5 Amp Driver. The MBC15161 requires a DC power supply of 12 volts to 48 volts. The PSA40V4A is the recommended Anaheim Automation power supply . The power supply must be ordered separately. Divide- by- 16 Maximum.

**Model MBC08081**

This microstep driver is a Single Axis, 8.3 Amp Driver. The MBC08081 requires a DC power supply of 24 volt to 85 volts. The PSA80V4A is the recommended Anaheim Automation power supply. The power supply must be ordered separately . Divide- by- 8 Maximum.

**Model PSA40V4A**

This is an unregulated 40VDC, 4A power supply.

**Model PSA65V5A**

This is an unregulated 65VDC, 5A power supply.

**Model PSA80V4A**

This is an unregulated 80VDC, 4A power supply.

**PIN DESCRIPTIONS TB1**

Pin#	Description
1	<b>Direction Anode (+):</b> This isolated input is used to change the direction of the motor. Physical direction also depends on the connection of the motor windings.
2	<b>Direction Cathode (-):</b>
3	<b>Step Clock Input Anode (+):</b> A positive going edge on this isolated input advances the motor one increment. The size of the increment is dependent on the Microstep Select Inputs of Switch 1.
4	<b>Step Clock Input Cathode (-):</b>
5	<b>ON/OFF Anode (+):</b> This isolated input is used to enable/disable the output section of the driver. When HIGH (open) the outputs are enabled. However, this input does not inhibit the step clock.
6	<b>ON/OFF Cathode (-)</b>
7	<b>+5 VDC:</b> This non-isolated output can be used to supply up to 100 mA of current to the isolated inputs. <b>Note: by doing this, isolation will be disabled.</b>
8	<b>0 VDC:</b> +5VDC return

**Table 1 - CONNECTOR TB1**

**PIN DESCRIPTIONS TB2**

Pin#	Description
1	<b>Phase 1A:</b> Phase 1 of the Step Motor
2	<b>Phase 1B:</b> Phase 3 of the Step Motor
3	<b>Phase 2A:</b> Phase 2 of the Step Motor
4	<b>Phase 2B:</b> Phase 4 of the Step Motor
5	Motor Ground

Table 2 - CONNECTOR TB2

PIN DESCRIPTIONS TB3

Pin#	Description
1	+VIN: Supply voltage input (24VDC - 85VDC).
2	Ground: Supply voltage ground.
3	Earth Ground

Table 3 - CONNECTOR TB3

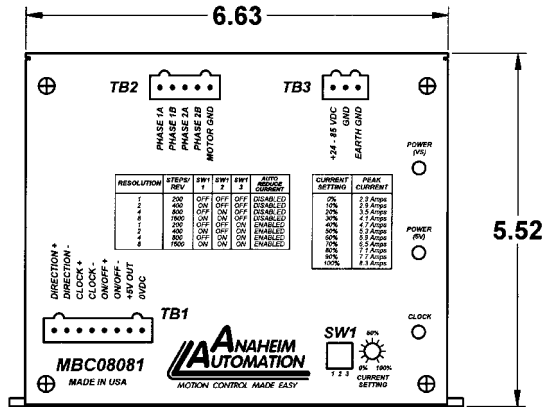
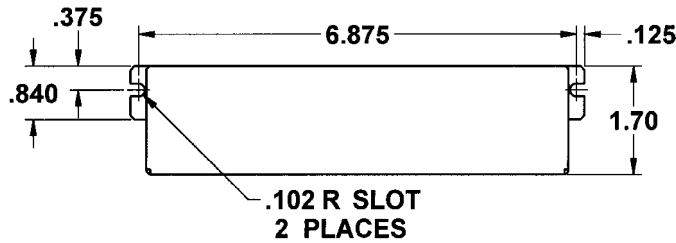

Dimension Drawing

TYPICAL HOOK-UPS FOR APPLICATION:

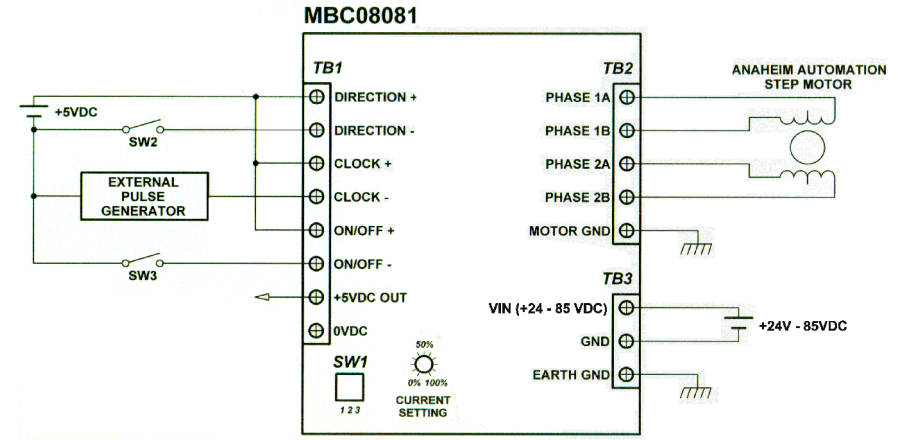

Figure 2 - Sample Hook Up for Current Sinking Inputs

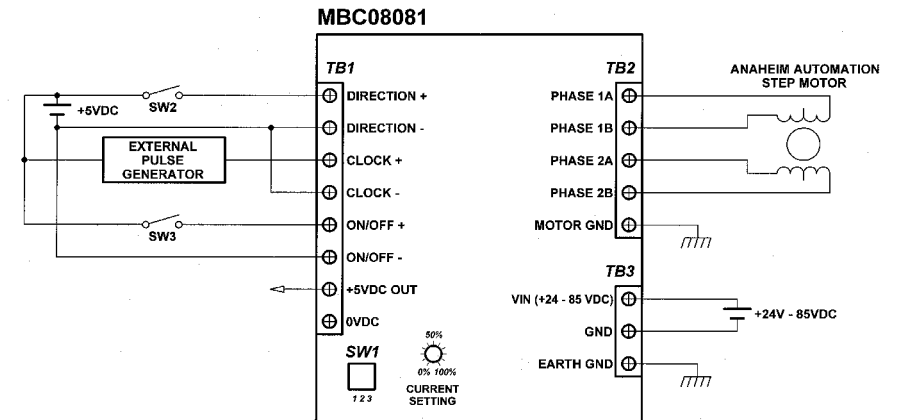

Figure 3 - Sample Hook Up for Current Sourcing Inputs

Optional: Non- Isolated +5Vdc Output can power MBC08081 Inputs but isolation is eliminated.

## SPECIFICATIONS

### ABSOLUTE MAXIMUM RATINGS

INPUT VOLTAGE: 24 TO +85 VDC

OUTPUT CURRENT: 8.3 AMPS PEAK

PLATE TEMPERATURE: 70° C

STORAGE TEMPERATURE: 40° TO +125° C

INPUT VOLTAGE (For isolated inputs): +5 TO +24 VDC

### ELECTRICAL SPECIFICATIONS

ITEM	MIN	TYP	MAX	UNITS
Input Voltage	24	65	85	V
Phase Output Current	1.6		5.8	A (RMS)
Phase Output Current	2.3		8.3	A (Peak)
Clock Frequency	0		100	kHz
Chopping Frequency	20	27	33	kHz
+5VDC Output	4.8	5	5.2	V
+5VDC Output	0		100	mA
Operation Temperature	0		70	°C

Table 4 - MBC08081 Electrical Specifications

## DETERMINING OUTPUT CURRENT

The output current for the motor used when microstepping is determined differently from that of a half/full unipolar driver. In the MBC08081, a sine/cosine output function is used in rotating the motor. The output current for a given motor is determined by the motors current rating *and* the configuration for how the motor is hooked up. There is a current adjustment potentiometer used to set the output current of the MBC08081. This sets the peak output current of the sine/cosine waves. The specified motor current (which is the Unipolar value) is multiplied by a factor of 1.0, 1.4, or 2.0 depending on the motor configuration (series, half-coil, or parallel).

### SETTING OUTPUT CURRENT

The output current on the MBC08081 is set by an onboard potentiometer. This potentiometer determines the per Phase peak output current of the driver. The relationship between the output current and the potentiometer value is as follows:

Peak Current	Potentiometer Setting	Peak Current	Potentiometer Setting
2.3 Amps	0%	5.9 Amps	60%
2.9 Amps	10%	6.5 Amps	70%
3.5 Amps	20%	7.1 Amps	80%
4.1 Amps	30%	7.7 Amps	90%
4.7 Amps	40%	8.3 Amps	100%
5.3 Amps	50%	--	--

Table 5 - Potentiometer values with respect to the output current

*Refer to Table 6 for specific motor current settings.*

## REDUCING OUTPUT CURRENT

Reducing the output current is accomplished by setting switch 3 of the DIP switch to the ON position and occurs approximately 1 second after the last positive going edge of the step clock input.

The amount of current per Phase in the reduction mode is 70% of the set current. When the current reduction circuit is activated, the current reduction resistor is paralleled with the current adjustment potentiometer. This lowers the total resistance value, and thus lowers the per Phase output current.

## MOTOR SELECTION

The MBC08081 is a Bipolar microstep driver working equally well with both Bipolar and Unipolar Motor Configurations, ( i.e. 8 and 4 lead motors and 6 lead center tapped motors).

*Step motors with low current ratings and high inductance will perform better at low speeds, providing higher low-end torque. Motors with high current ratings and low inductance will perform better at higher speeds, providing higher high-end torque.*

Since the MBC08081 is a constant current source, it is not necessary to use a motor that is rated at the same voltage as the supply voltage. What is important is that the MBC08081 is set to the appropriate current level based on the motor being used.

Higher voltages will cause the current to flow faster through the motor coils. This in turn means higher step rates can be achieved. *Care should be taken not to exceed the maximum voltage of the driver.*

## STEP MOTOR CONFIGURATIONS

Step motors can be configured as 4, 6, or 8 leads. Each configuration requires different currents. Shown below are different lead configurations and the procedures to determine their output current.

## 6 Lead Motors

When configuring a 6 lead motor in a **half-coil configuration** (connected from one end of the coil to the center tap), multiply the specified per Phase (or unipolar) current rating by 1.4 to determine the current setting potentiometer value. This configuration will provide more torque at higher speeds when compared to the series configuration.

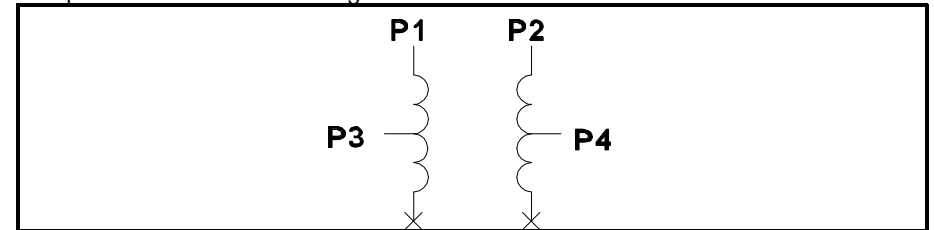

When configuring the motor in a **series configuration** (connected from end to end with the center tap floating) use the specified per Phase (or unipolar) current rating to determine the current setting potentiometer value.

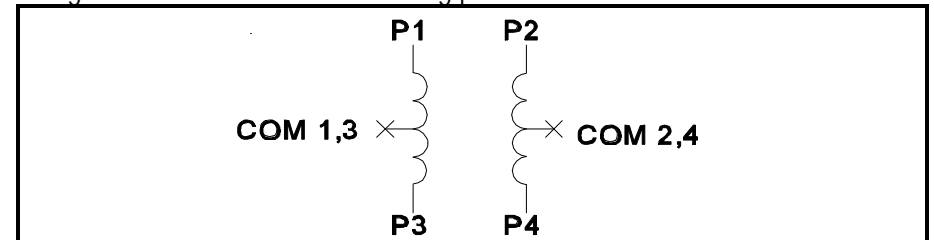

**WARNING!** Step motors will run hot even when configured correctly. Damage may occur to the motor if a higher than specified current is used. Most specified motor currents are maximum values. Care should be taken to not exceed these ratings.

## 4 Lead Motors

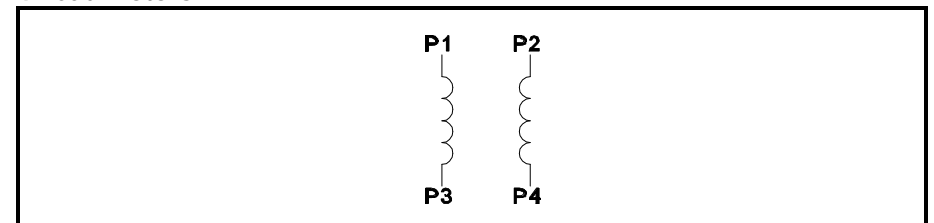

Multiply the specified **series** motor current by 1.4 to determine the current adjustment potentiometer value. Four Lead Motors are usually rated with their appropriate series current, as opposed to the *Phase Current* which is the rating for 6 and 8 lead motors.

## 8 Lead Motors

**Series Connection:** When configuring the motor windings in series, use the per Phase (or unipolar) current rating to determine the current setting potentiometer value.

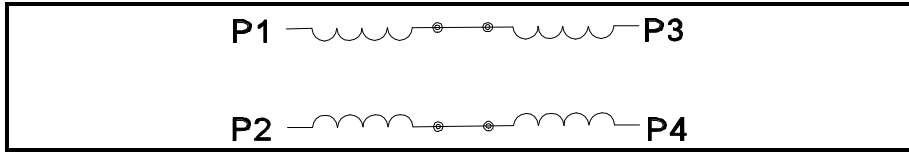

**Parallel Connection:** When configuring the motor windings in parallel, multiply the per Phase (or unipolar) current rating by 2.0 to determine the current setting potentiometer value.

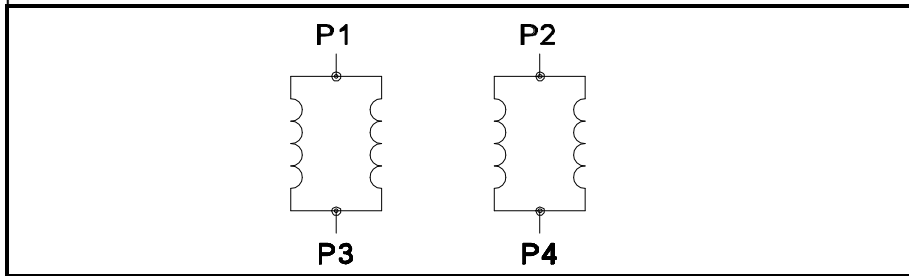

**NOTE:** After the current has been determined, according to the motor connections above, follow the procedure Determining Output Current above to find the current value. Then use Table 3 to choose the proper setting on the current setting potentiometer.

## CONNECTING THE STEP MOTOR

Phase 1 and 3 of the Step Motor is connected between pins 1 and 2 on connector TB2. Phase 2 and 4 of the Step Motor is connected between pins 3 and 4 on connector TB2. The motor's case can be grounded to pin 5 on connector TB2. Refer to Figure 2 & 3 for TYPICAL APPLICATION HOOK-UP

**NOTE:** The physical direction of the motor with respect to the direction input will depend on the connection of the motor windings. To reverse the direction of the motor with respect to the direction input, switch the wires on Phase 1 and Phase 3.

**WARNING:** Do not connect or disconnect motor wires while power is applied!

## CONNECTING POWER

Pins 1 and 2 on connector TB3 are used to connect the DC Power Supply to the MBC08081. *Wire size used to connect the power source to the driver should be at least 16 gauge.* Heavier wire should be used for longer distances between the power supply and the driver. The power supply requirements are as follows:

*Switching Power Supplies and regulated linears with overcurrent protection are not recommended because of their inability to handle surge currents. Adding a capacitor to the output will alleviate this problem.*

*When multiple drivers are run from one power supply, each driver should have separate power and ground wires that connect directly to the output capacitor of the power supply.*

Refer to Figure 2 & 3 for TYPICAL APPLICATION HOOK-UP.

**WARNING:** When using an unregulated power supply, care should be taken to ensure that the output voltage DOES NOT exceed the maximum driver input voltage because of line voltage fluctuations. It is recommended that an input line filter be used on the power supply to limit voltage spikes to the driver.

**NOTE:** To connect the drivers's case to earth ground use, pin 3 on connector TB3.

## Anaheim Automation Step Motor Selection Guide

Part Number	Unipolar Rating [ Amps ]	Series Peak Rating [ Amps ]	Parallel Peak Rating [ Amps ]	Series Current Setting Pot. Value (%)	Parallel Current Setting Pot. Value (%)
23L104	2	2	4	N/A	30
34N207	3.5	3.5	7	20	80
23L108	4	4	8	30	95
23L210	5	5	10	45	100
42N112	6	6	12	60	100
42N214	7	7	14	80	100
42N115	7.5	7.5	15	85	100
34N416	8	8	16	95	100
42D219	9.2	9.2	18.4	100	100

TABLE 6 - Table Selection for Anaheim Automation Motor Current Settings.

## MICROSTEP SELECTION (SW1 SETTINGS)

The number of microsteps per step is selected by switches 1 and 2, of the DIP switch. Table 5 shows the standard resolution values along with the associated inputs for the select switches 1 and 2. The standard waveforms are sinusoidal.

Resolution	Steps/ Rev	Select 1	Select 2	Select 3	Auto Reduce Current
1	200	OFF	OFF	OFF	DISABLED
2	400	ON	OFF	OFF	DISABLED
4	800	OFF	ON	OFF	DISABLED
8	1600	ON	ON	OFF	DISABLED
1	200	OFF	OFF	ON	ENABLED
2	400	ON	OFF	ON	ENABLED
4	800	OFF	ON	ON	ENABLED
8	1600	ON	ON	ON	ENABLED

TABLE 7 - Microstep Selection on Switch 1

## OPTICALLY ISOLATED INPUTS

The following inputs to the MBC08081 are Optically Isolated.

Item	Pin #
Direction	1 & 2
Clock	3 & 4
On/Off	5 & 6

To Enable an input, apply a DC voltage source of +5VDC to +24VDC across the inputs. The Anodes (+) are pins 1,3,and 5 and the Cathodes (-) are pins 2, 4, and 6



## PERFORMANCE CURVES

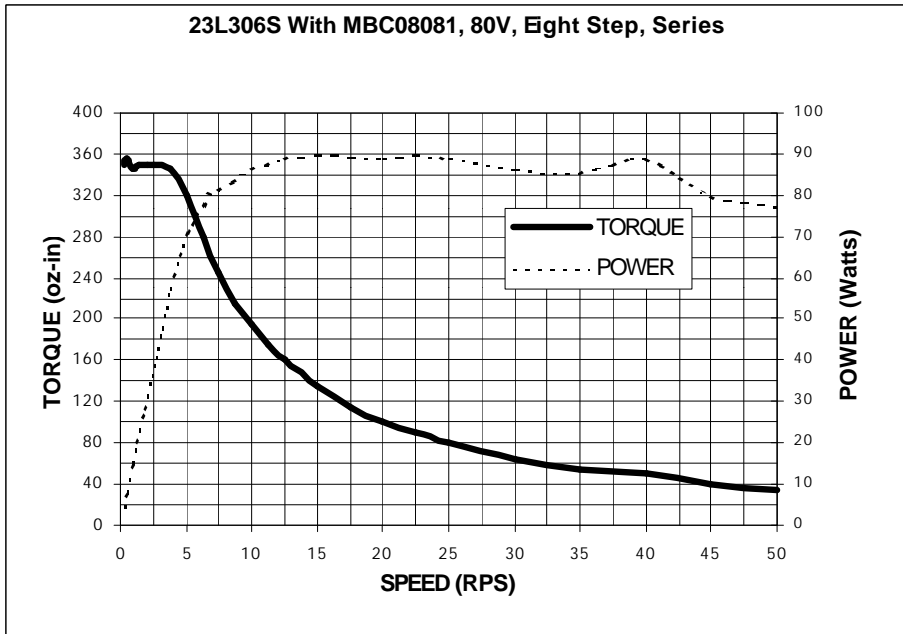

## PERFORMANCE CURVES

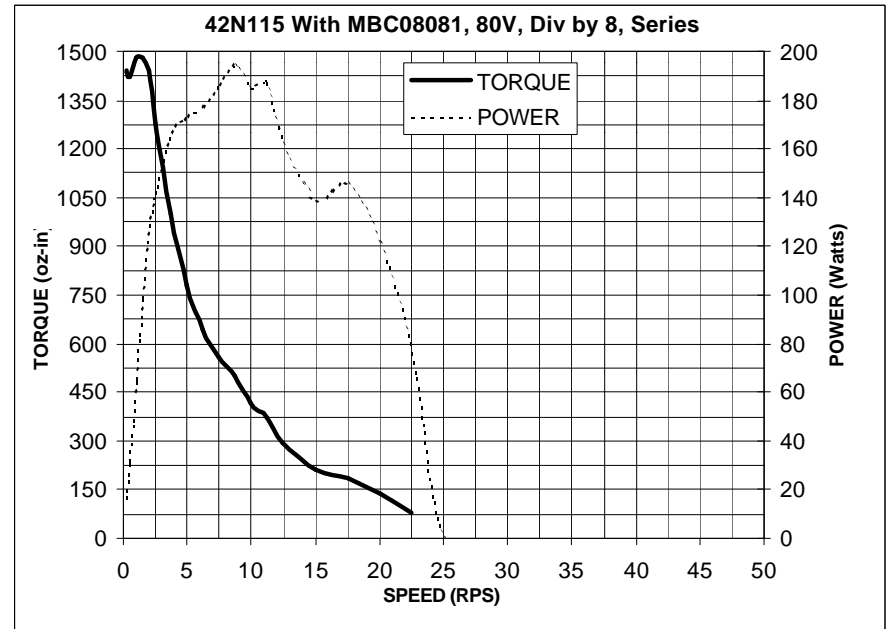
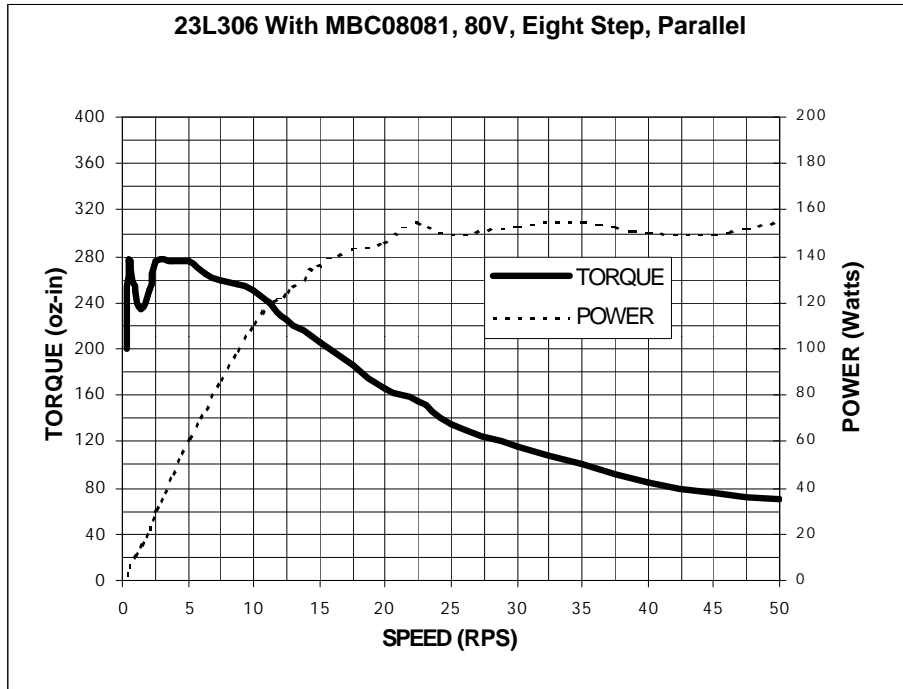
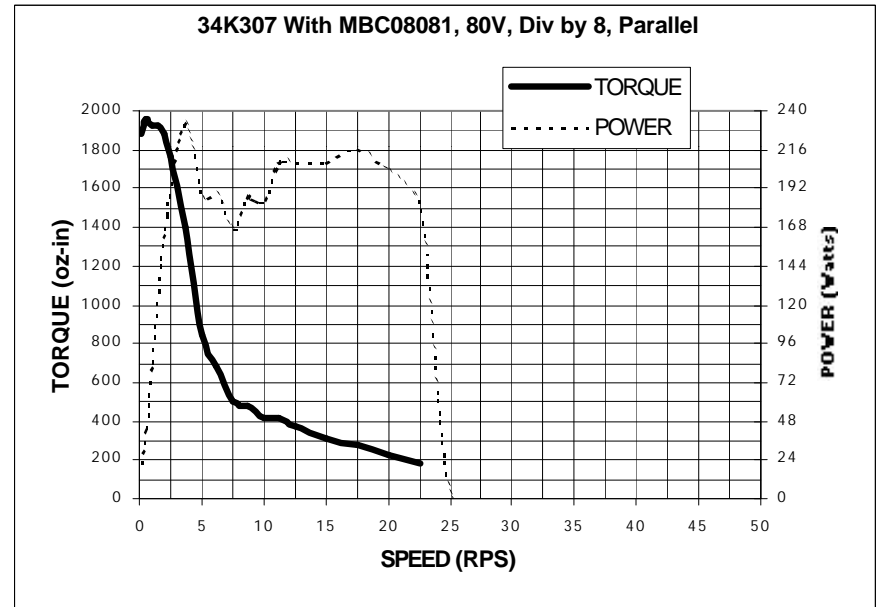

NOTES



910 E. Orangefair Lane  
Anaheim, CA 92801  
TEL (714) 992-6990  
FAX (714) 992-0471

E-Mail: [sales@anaheimautomation.com](mailto:sales@anaheimautomation.com)

[www.anaheimautomation.com](http://www.anaheimautomation.com)